

# DRUM STORAGE RACK - DRK-2-3

APPROX WEIGHT: 231.48 lbs.  
 DOES NOT INCLUDE WEIGHT OF POWER OR PACKAGING!!!

\*\*\* ANY ADDITIONS, DELETIONS, OR OMISSIONS MUST BE CORRECTED ON THIS DRAWING AS THIS DRAWING WILL BE CONSIDERED ALL INCLUSIVE \*\*\*

ALL GRAPHICS PROVIDED ARE FOR REFERENCE ONLY. IF CERTAIN DIMENSIONS ARE CRITICAL PLEASE VERIFY THOSE DIMENSIONS WITH YOUR SALESPERSON

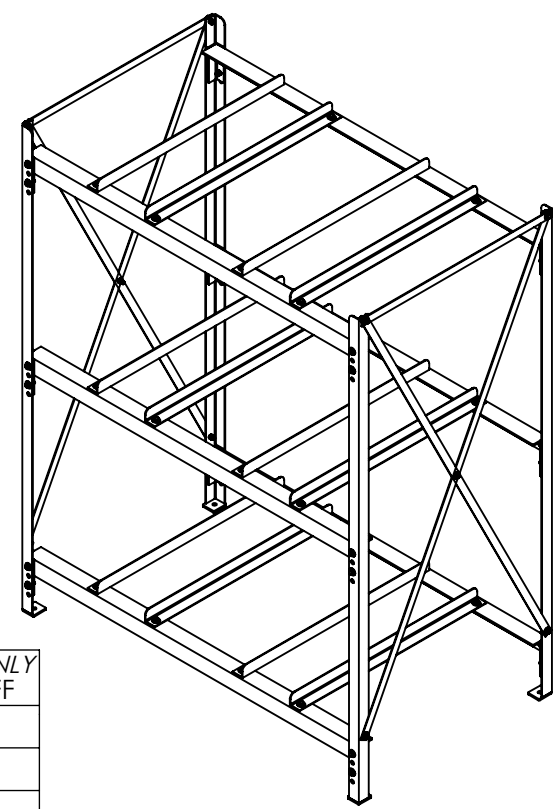
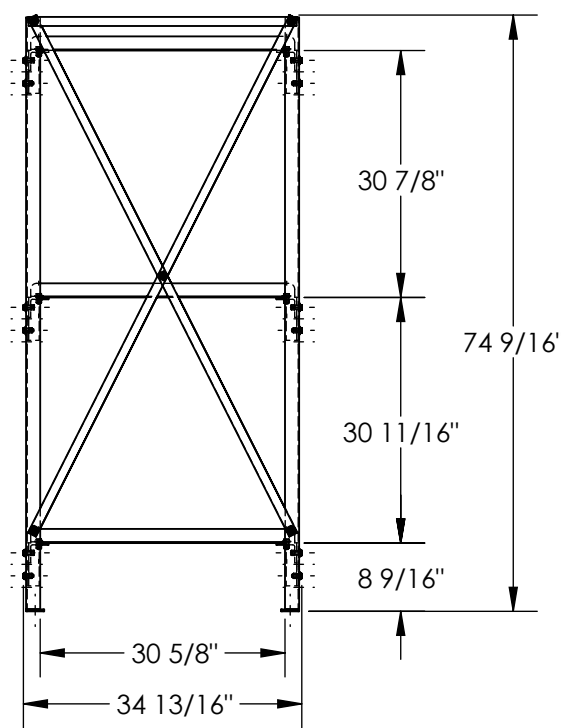
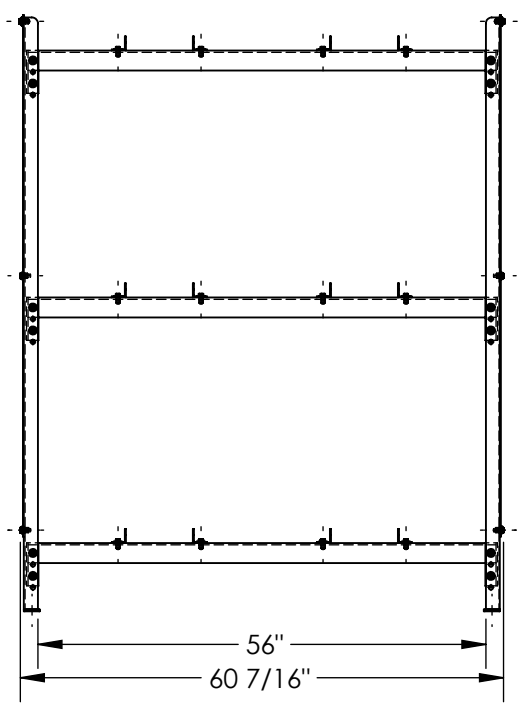

## STANDARD FEATURES

- MODEL NUMBER IS DRK-2-3
- OVERALL WIDTH IS 60 7/16"
- USABLE WIDTH IS 56"
- OVERALL LENGTH IS 34 13/16"
- USABLE LENGTH IS 30 5/8"
- OVERALL HEIGHT IS 74 9/16"
- MAX CAPACITY IS 4,800 LBS.
- CAPACITY PER SHELF: 1,600 LBS.
- CONSTRUCTED OF HEAVY DUTY STEEL ANGLE
- CROSS BRACING IS PROVIDED FOR EXTRA STRENGTH
- ALLOWS FORKLIFT ENTRY FROM THE FRONT OR REAR
- UPRIGHTS KEEP DRUMS FROM ACCIDENTAL ROLL OFF
- ROUNDED CRADLE EDGES PREVENT DRUMS FROM PUNCTURE
- (4) ANCHOR PADS HELP TO PREVENT TIPPING
- FRAME: TOUGH BAKED IN POWDER COATED YELLOW FINISH
- CROSS BRACES: TOUGH BAKED IN POWDER COATED BLUE FINISH
- SHIPS KNOCKED DOWN

## SPECIAL FEATURES

NONE

FOR INTERNAL USE ONLY  
 PROJECT SIGN OFF

SALES	
ENG.	
FAB.	
POWER	

DIMENSION TOLERANCE ± 1/4"

<b>APPROVAL</b>	I, THE UNDERSIGNED, AGREE THAT THE PRODUCT AS REPRESENTED SATISFIES DESIGN AND DIMENSION REQUIREMENTS. I ALSO ACKNOWLEDGE MY DUTY TO CONFIRM PRODUCT AND INSTALLATION COMPLIANCE WITH ALL APPLICABLE FEDERAL, STATE AND LOCAL REGULATIONS AND STANDARDS.	
	<b>ANY MODIFIED UNITS ARE NON-RETURNABLE</b>	
	<input type="checkbox"/> As drawn	<input type="checkbox"/> As marked
	Signed: _____	Date: _____
	Printed Name: _____	
<b>LEAD TIME WILL START UPON RECEIPT OF SIGNED APPROVAL DRAWING</b>		

DISTRIBUTOR'S NAME:		P.O.#
<b>VESTIL MANUFACTURING</b>		X
		W.O.#
DRAWN BY: THW		X
DATE: 07/10/19		SALES: X
REFERENCE: X	SCALE: 1:24	FILE NAME:
QUOTED LEAD TIME: X	QUOTE #	40-007-086
	X	